



Lecture Modelling of Hydro-systems

Mass Transport Process Part II

Dr. Haibing Shao
Lecture room HSZ-403, TU Dresden
Dresden, 03.06.2022

Table of Content

- Finite element discretization in space
- Finite difference discretization in time
- Linear equation assembly
- Impose the Boundary condition
- Peclet and Courant number (stability)

Basics of Finite Element Method

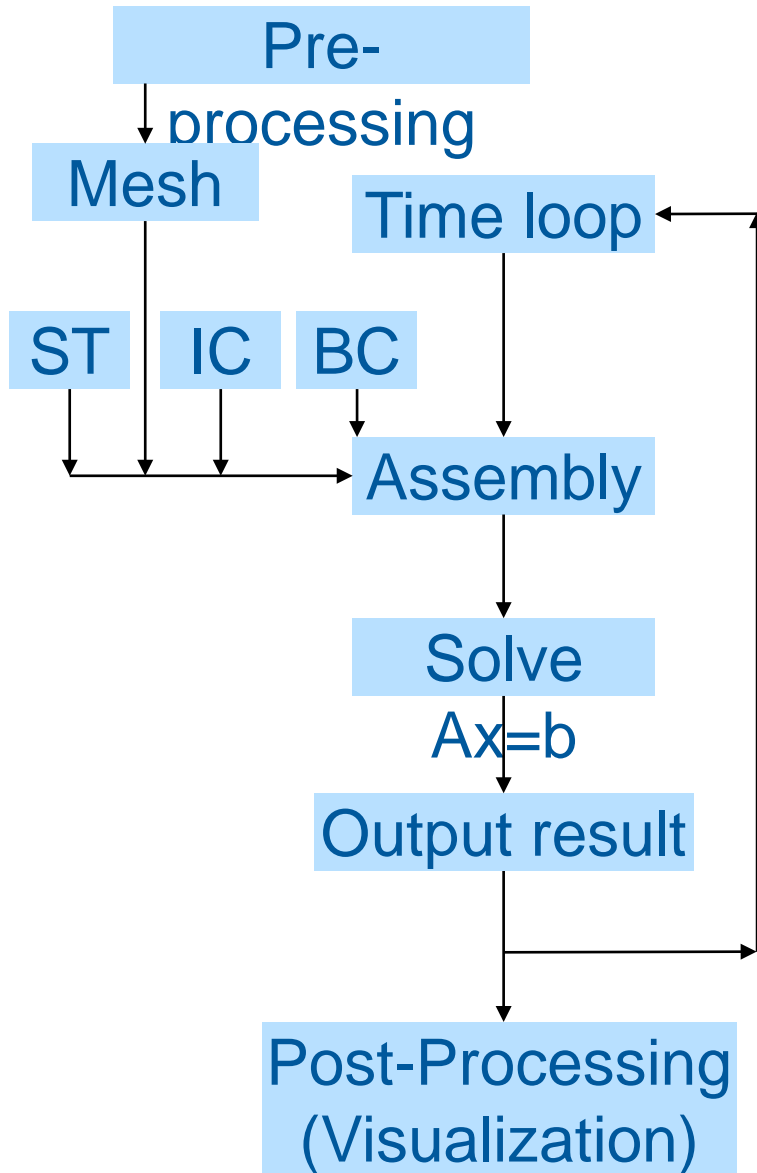

In simple words, we convert the PDE from

$$\frac{\partial c}{\partial t} + \nabla \cdot (-D \nabla \vec{c} + \vec{v}c) = s.$$

, using the topology:

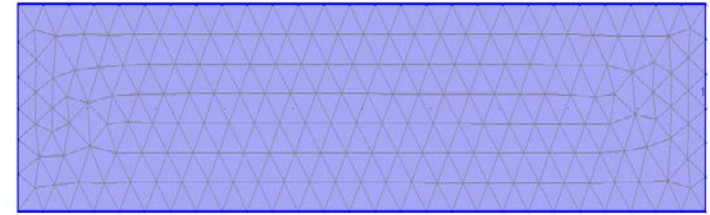

, so that it is converted to linear equation

$Ax = b$:

$$\begin{bmatrix} a_{11} & a_{12} & a_{13} & \cdots & a_{1n} \\ a_{21} & a_{22} & a_{23} & \cdots & a_{2n} \\ a_{31} & a_{32} & a_{33} & \cdots & \cdot \\ \cdot & \cdot & \cdot & \cdot & \cdot \\ a_{m1} & a_{m2} & a_{m3} & \cdots & a_{mn} \end{bmatrix} \begin{bmatrix} x_1 \\ x_2 \\ x_3 \\ \cdot \\ x_n \end{bmatrix} = \begin{bmatrix} b_1 \\ b_2 \\ b_3 \\ \cdot \\ b_m \end{bmatrix}$$

, and solve it, so that we get:

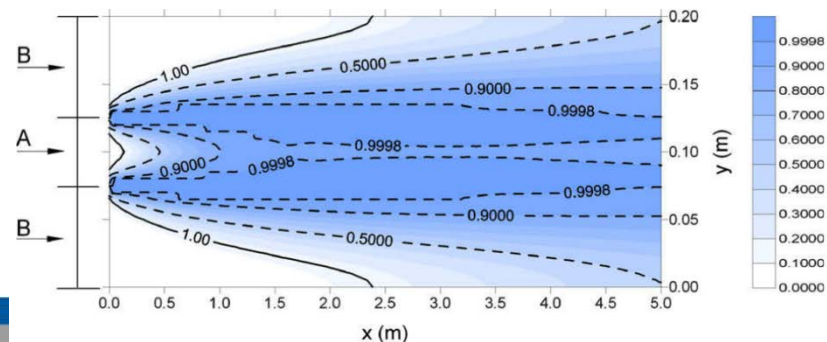

Finite element in space

The numerical method of FEM employs the Method of Weighted Residuals (MWR) to find the solution of a PDE.

MWR can be divided into 3 steps:

- 1) Approximation of the unknown function by a trial solution;
- 2) Definition of weighting functions;
- 3) Derivation of a system of algebraic equations, and solve it to find the approximation solution.

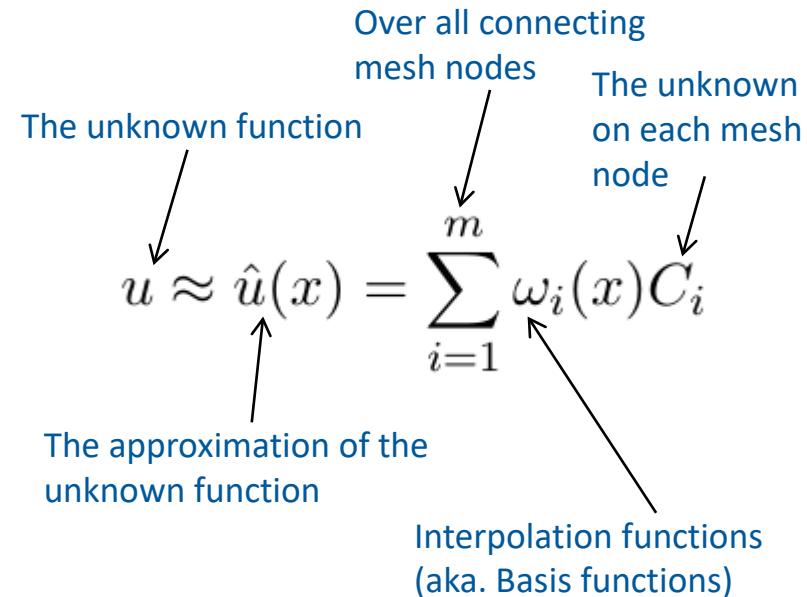

$$\frac{\partial}{\partial t} u + \nabla \cdot \Phi^u = q^u$$

Let Φ^u be the flux vector of conservative quantity u and q^u the source/sink term (see our first lecture about GROUNDWATER_FLOW process)

Applying the approximation, we get the weak form of the above equation as

$$\int_{\Omega} \omega_i \frac{\partial u}{\partial t} d\Omega + \int_{\Omega} \omega_i \nabla \cdot \Phi^u d\Omega = \int_{\Omega} \omega_i q^u d\Omega$$

In order to get rid of the special derivative of flux term, we apply the Green's theorem

$$\int_{\Omega} \omega_i \frac{\partial u}{\partial t} d\Omega - \int_{\Omega} \Phi^u \cdot \nabla \omega_i d\Omega + \oint_{\partial\Omega} \omega_i \Phi^u dS = \int_{\Omega} \omega_i q^u d\Omega$$

Finite element in space

$$\int_{\Omega} \omega_i \frac{\partial u}{\partial t} d\Omega - \int_{\Omega} \Phi^u \cdot \nabla \omega_i d\Omega + \oint_{\partial\Omega} \omega_i \Phi^u dS = \int_{\Omega} \omega_i q^u d\Omega$$

After Green's transformation, we temporarily focusing on the space approximation, assuming time not changing.

Approximation of unknown u

$$\hat{u}(t, x) = \sum_j \omega_j(x) u_j(t)$$

Approximation of the flux of unknown u

$$\hat{\Phi}(t, x) = \sum_j \omega_j(x) \Phi_j(t)$$

So that the above equation becomes

$$\sum_i \frac{du_j}{dt} \underbrace{\int_{\Omega} \omega_i \omega_j d\Omega}_{M_{ij}} - \sum_i \Phi^u \cdot \underbrace{\int_{\Omega} \omega_j \nabla \omega_i d\Omega}_{K_{ij}} + \underbrace{\oint_{\partial\Omega} \omega_i \Phi^u dS}_{\text{nodal based}} = \int_{\Omega} \omega_i q^u d\Omega$$

$$M_{ij} = \int_{\Omega} \omega_i \omega_j d\Omega$$

This part is applied on element **Mass Matrix**

“shape-shape”

$$K_{ij} = \int_{\Omega} \omega_j \nabla \omega_i d\Omega$$

This part is applied on element **Stiffness Matrix**

“shape-dshape”

This part is nodal based

This part should zero out.
“When time is infinitely short, how much flowing-in should equal to how much flowing-out”

Shape functions (1D line element)

First let's explore how the shape function is calculated for a 1D line element.

A simple approximation of the unknown function $u(x)$ can be obtained by linear approximation.

$$\hat{u}(x) = a_1 + a_2x$$

On the two ends of the line element, we assume that our unknown function produces u_1 and u_2 at position x_1 and x_2 .

$$u_1 = a_1 + a_2x_1$$

$$u_2 = a_1 + a_2x_2$$

Write in a linear algebra form

$$\begin{pmatrix} u_1 \\ u_2 \end{pmatrix} = \begin{bmatrix} 1 & x_1 \\ 1 & x_2 \end{bmatrix} \begin{pmatrix} a_1 \\ a_2 \end{pmatrix}$$

Make an inversion of the expression, we get the a_1 and a_2 value dependency on u_1 and u_2 .

$$\begin{pmatrix} a_1 \\ a_2 \end{pmatrix} = \frac{1}{x_2 - x_1} \begin{bmatrix} x_2 & -x_1 \\ -1 & 1 \end{bmatrix} \begin{pmatrix} u_1 \\ u_2 \end{pmatrix}$$

Write back to the standard form

$$a_1 = \frac{1}{x_2 - x_1}(x_2u_1 - x_1u_2)$$

Insert back here

$$a_2 = \frac{1}{x_2 - x_1}(-u_1 + u_2)$$

Then we get the expression of approximated solution based on the location

$$\hat{u}(x) = \underbrace{\frac{x_2 - x}{x_2 - x_1}}_{N_1(x)} u_1 + \underbrace{\frac{x - x_1}{x_2 - x_1}}_{N_2(x)} u_2 = N_1(x)u_1 + N_2(x)u_2$$

$N_1(x)$ and $N_2(x)$ are the so-called shape functions.

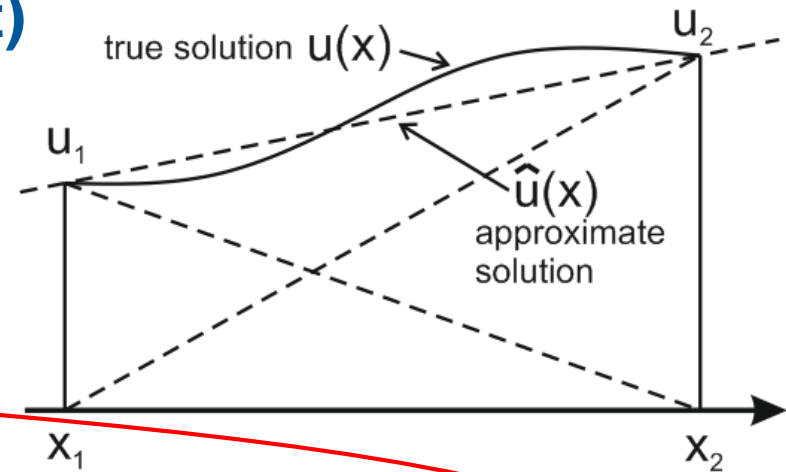

Shape functions (1D line element, higher orders)

Linear

Approximation $\hat{u}(x) = a_1 + a_2x$

Shape Function $N_1(x) = \frac{x_2 - x}{x_2 - x_1}$

$$N_2(x) = \frac{x - x_1}{x_2 - x_1}$$

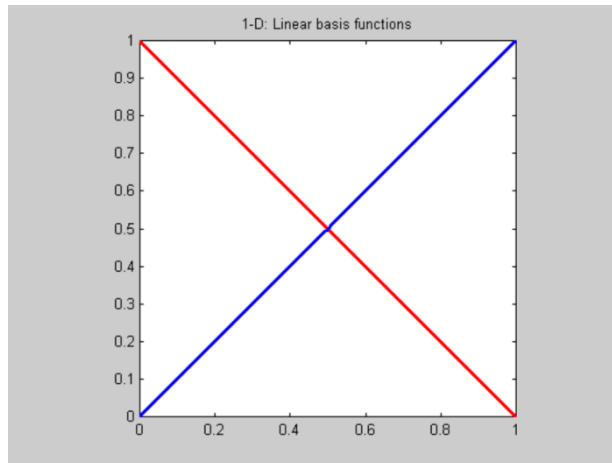

Quadratic

$$\hat{u}(x) = a_1 + a_2x + a_3x^2$$

$$N_1(x) = \frac{(x - x_2)(x - x_3)}{(x_1 - x_2)(x_1 - x_3)}$$

$$N_2(x) = \frac{(x - x_1)(x - x_3)}{(x_2 - x_1)(x_2 - x_3)}$$

$$N_3(x) = \frac{(x - x_1)(x - x_2)}{(x_3 - x_2)(x_3 - x_1)}$$

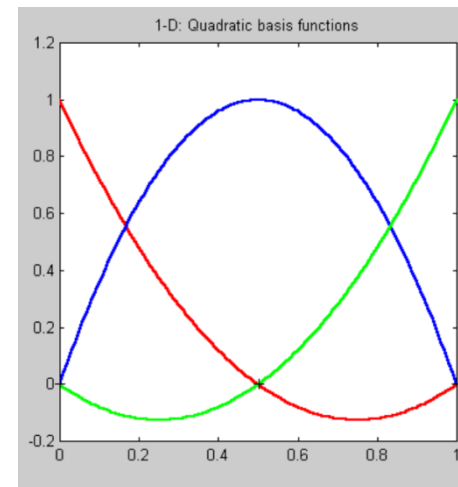

Shape functions (2D line triangle element)

Approximation: $\hat{u}(x, y) = a_1 + a_2x + a_3y$

The interpolation writes as

$$u_1 = a_1 + a_2x_1 + a_3y_1$$

$$u_2 = a_1 + a_2x_2 + a_3y_2$$

$$u_3 = a_1 + a_2x_3 + a_3y_3$$

Write it in the matrix-vector form

$$\begin{Bmatrix} u_1 \\ u_2 \\ u_3 \end{Bmatrix} = \begin{bmatrix} 1 & x_1 & y_1 \\ 1 & x_2 & y_2 \\ 1 & x_3 & y_3 \end{bmatrix} \begin{Bmatrix} a_1 \\ a_2 \\ a_3 \end{Bmatrix}$$

Inversion of the above relationship will give

$$\begin{Bmatrix} a_1 \\ a_2 \\ a_3 \end{Bmatrix} = \frac{1}{2A} \begin{bmatrix} x_2y_3 - x_3y_2 & x_3y_1 - x_1y_3 & x_1y_2 - x_2y_1 \\ y_2 - y_3 & y_3 - y_1 & y_1 - y_2 \\ x_3 - x_2 & x_1 - x_3 & x_2 - x_1 \end{bmatrix} \begin{Bmatrix} u_1 \\ u_2 \\ u_3 \end{Bmatrix}$$

With A the surface area of the triangle

$$A = \frac{1}{2} \begin{vmatrix} x_1 & y_1 & 1 \\ x_2 & y_2 & 1 \\ x_3 & y_3 & 1 \end{vmatrix}$$

So again our shape function act like

$$\hat{u}(x, y) = N_1(x, y)u_1 + N_2(x, y)u_2 + N_3(x, y)u_3$$

They can be explicitly calculated as

$$N_1(x, y) = \frac{1}{2A} [(x_2y_3 - x_3y_2) + (y_2 - y_3)x + (x_3 - x_2)y]$$

$$N_2(x, y) = \frac{1}{2A} [(x_3y_1 - x_1y_3) + (y_3 - y_1)x + (x_1 - x_3)y]$$

$$N_3(x, y) = \frac{1}{2A} [(x_1y_2 - x_2y_1) + (y_1 - y_2)x + (x_2 - x_1)y]$$

Or in the matrix vector form

$$\begin{Bmatrix} N_1 \\ N_2 \\ N_3 \end{Bmatrix} = \frac{1}{2A} \begin{bmatrix} x_2y_3 - x_3y_2 & y_2 - y_3 & x_3 - x_2 \\ x_3y_1 - x_1y_3 & y_3 - y_1 & x_1 - x_3 \\ x_1y_2 - x_2y_1 & y_1 - y_2 & x_2 - x_1 \end{bmatrix} \begin{Bmatrix} 1 \\ x \\ y \end{Bmatrix}$$

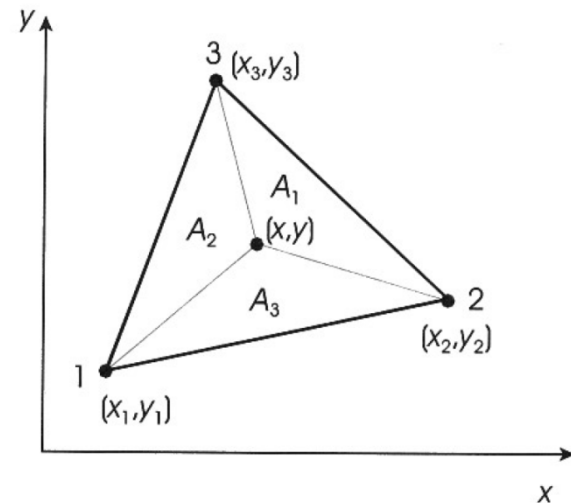

Finite difference in time

We start from the mass transport governing equation

$$\underbrace{\frac{\partial C}{\partial t}}_{\substack{\text{Change over time} \\ \text{Time discretization}}} + \underbrace{\nabla(-D \cdot \nabla C)}_{\substack{\text{Dispersion/Diffusion} \\ \text{Spatial discretization}}} + \underbrace{v \cdot \nabla C}_{\text{Advection}} = Q \quad \left. \vphantom{\frac{\partial C}{\partial t}} \right\} \text{Source and Sink Term, i.e. decay and reaction}$$

- Make a difference of previous and current time step value for primary unknown.
- For the time discretization part, we use forward Euler method:
- For all C values in the spatial discretization part, we apply linear interpolation btw previous and current values:

C^n – previous time step value

C^{n+1} – current time step value

$$\frac{\partial C}{\partial t} = \frac{C^{n+1} - C^n}{\Delta t}$$

$$C = (1 - \theta)C^n + \theta C^{n+1}$$

$\theta = 1$: C taken from the current time step, AKA **implicit scheme**.

$\theta = 0$: C taken from the previous time step, AKA **explicit scheme**.

Finite difference in time

We start from the mass transport governing equation

$$\underbrace{\frac{\partial C}{\partial t}}_{\substack{\text{Change over time} \\ \text{Time discretization}}} + \underbrace{\nabla(-D \cdot \nabla C)}_{\substack{\text{Dispersion/Diffusion} \\ \text{Spatial discretization}}} + \underbrace{v \cdot \nabla C}_{\text{Advection}} = Q \quad \left. \vphantom{\frac{\partial C}{\partial t}} \right\} \text{Source and Sink Term, i.e. decay and reaction}$$

- Make a difference of previous and current time step value for primary unknown.
- For the time discretization part, we use forward Euler method:
- For all C values in the spatial discretization part, we apply linear interpolation btw previous and current values:

C^n – previous time step value
 C^{n+1} – current time step value

$$\frac{\partial C}{\partial t} = \frac{C^{n+1} - C^n}{\Delta t}$$

$$C = (1 - \theta)C^n + \theta C^{n+1}$$

Handle the time derivative

$$\frac{\partial C}{\partial t} + \nabla(-D \cdot \nabla C) + v \cdot \nabla C = Q$$

$$\frac{C^{n+1} - C^n}{\Delta t} + \nabla(-D \cdot \nabla((1 - \theta)C^n + \theta C^{n+1})) + v \cdot \nabla((1 - \theta)C^n + \theta C^{n+1}) = Q$$

We know all the previous time step value, so keep known things to the RHS and unknown things to the other.

$$\begin{aligned} & \frac{1}{\Delta t} C^{n+1} + \nabla(-D \cdot \nabla \theta C^{n+1}) + v \cdot \nabla(\theta C^{n+1}) \\ &= \frac{1}{\Delta t} C^n - (\nabla(-D \cdot \nabla(1 - \theta)C^n) + v \cdot \nabla((1 - \theta)C^n)) + Q \end{aligned}$$

Handle the space derivative

$$\begin{aligned} & \frac{1}{\Delta t} C^{n+1} + \nabla(-D \cdot \nabla \theta C^{n+1}) + v \cdot \nabla(\theta C^{n+1}) \\ = & \frac{1}{\Delta t} C^n - (\nabla(-D \cdot \nabla(1 - \theta)C^n) + v \cdot \nabla((1 - \theta)C^n)) + Q \end{aligned}$$

Mass Term $\frac{1}{\Delta t} C^{n+1} \Rightarrow \int_{\Omega^e} \mathbf{N} \cdot C^{n+1} \cdot \mathbf{N} d\Omega \Rightarrow \int_{\Omega^e} \mathbf{N} \cdot \mathbf{N} d\Omega \cdot C^{n+1}$

Dispersion/
Diffusion $\nabla(-D \cdot \nabla(\theta C^{n+1})) \Rightarrow \int_{\Omega^e} \nabla \mathbf{N} \cdot (-D) \nabla \mathbf{N}^T d\Omega^e \cdot \theta C^{n+1}$

Advection $v \cdot \nabla(\theta C^{n+1}) \Rightarrow \int_{\Omega^e} \mathbf{N} \cdot (\theta v C^{n+1}) \nabla \mathbf{N}^T d\Omega^e \Rightarrow \int_{\Omega^e} \mathbf{N} \cdot (v) \nabla \mathbf{N}^T d\Omega^e \cdot \theta C^{n+1}$

Handle the space derivative

$$\begin{aligned} & \frac{1}{\Delta t} C^{n+1} + \nabla(-D \cdot \nabla \theta C^{n+1}) + v \cdot \nabla(\theta C^{n+1}) \\ = & \frac{1}{\Delta t} C^n - (\nabla(-D \cdot \nabla(1 - \theta)C^n) + v \cdot \nabla((1 - \theta)C^n)) + Q \end{aligned}$$

Mass Term $\frac{1}{\Delta t} C^{n+1} \Rightarrow \int_{\Omega^e} \mathbf{N} \cdot C^{n+1} \cdot \mathbf{N} d\Omega \Rightarrow \underbrace{\int_{\Omega^e} \mathbf{N} \cdot \mathbf{N} d\Omega}_{\text{Mass Matrix}} \cdot C^{n+1}$

Dispersion/
Diffusion $\nabla(-D \cdot \nabla(\theta C^{n+1})) \Rightarrow \underbrace{\int_{\Omega^e} \nabla \mathbf{N} \cdot (-D) \nabla \mathbf{N}^T d\Omega^e}_{\text{Dispersion Matrix}} \cdot \theta C^{n+1}$

Advection $v \cdot \nabla(\theta C^{n+1}) \Rightarrow \int_{\Omega^e} \mathbf{N} \cdot (\theta v C^{n+1}) \nabla \mathbf{N}^T d\Omega^e \Rightarrow \underbrace{\int_{\Omega^e} \mathbf{N} \cdot (v) \nabla \mathbf{N}^T d\Omega^e}_{\text{Advection Matrix}} \cdot \theta C^{n+1}$

Handle the space derivative

$$\frac{1}{\Delta t} C^{n+1} + \nabla(-D \cdot \nabla \theta C^{n+1}) + v \cdot \nabla(\theta C^{n+1})$$

$$= \frac{1}{\Delta t} C^n - (\nabla(-D \cdot \nabla(1 - \theta)C^n) + v \cdot \nabla((1 - \theta)C^n)) + Q$$

$$\Rightarrow \underbrace{\int_{\Omega^e} \mathbf{N} \cdot \mathbf{N} d\Omega}_{\text{Mass Matrix}} \cdot C^{n+1}$$

Mass Matrix

$$\Rightarrow \underbrace{\int_{\Omega^e} \nabla \mathbf{N} \cdot (-D) \nabla \mathbf{N}^T d\Omega^e}_{\text{Dispersion Matrix}} \cdot \theta C^{n+1}$$

Dispersion Matrix

$$\Rightarrow \underbrace{\int_{\Omega^e} \mathbf{N} \cdot (v) \nabla \mathbf{N}^T d\Omega^e}_{\text{Advection Matrix}} \cdot \theta C^{n+1}$$

Advection Matrix



$$\frac{1}{\Delta t} M \cdot C^{n+1} + Disp \cdot \theta C^{n+1} + Adv \cdot \theta C^{n+1}$$

$$= \frac{1}{\Delta t} M \cdot C^n + Disp \cdot (1 - \theta) C^n + Adv \cdot (1 - \theta) C^n + Q$$



$$\frac{1}{\Delta t} M \cdot C^{n+1} + (Disp + Adv) \cdot \theta C^{n+1}$$

$$= \frac{1}{\Delta t} M \cdot C^n + (Disp + Adv) \cdot (1 - \theta) C^n + Q$$

$$K = Disp + Adv$$

$$\left(\frac{1}{\Delta t} M + \theta K \right) C^{n+1}$$

$$= \left(\frac{1}{\Delta t} M + (1 - \theta) K \right) \cdot C^n + Q$$



$$Ax = b$$

$$\begin{bmatrix} a_{11} & a_{12} & a_{13} & \dots & a_{1n} \\ a_{21} & a_{22} & a_{23} & \dots & a_{2n} \\ a_{31} & a_{32} & a_{33} & \dots & \cdot \\ \cdot & \cdot & \cdot & \cdot & \cdot \\ a_{m1} & a_{m2} & a_{m3} & \dots & a_{mn} \end{bmatrix} \begin{bmatrix} x_1 \\ x_2 \\ x_3 \\ \cdot \\ x_n \end{bmatrix} = \begin{bmatrix} b_1 \\ b_2 \\ b_3 \\ \cdot \\ b_m \end{bmatrix}$$



Linear equation assembly

$$\left(\frac{1}{\Delta t}M + \theta K\right)C^{n+1} = \left(\frac{1}{\Delta t}M + (1 - \theta)K\right) \cdot C^n + Q$$

$$Ax = b$$

$$\begin{bmatrix} a_{11} & a_{12} & a_{13} & \cdots & a_{1n} \\ a_{21} & a_{22} & a_{23} & \cdots & a_{2n} \\ a_{31} & a_{32} & a_{33} & \cdots & \cdot \\ \cdot & \cdot & \cdot & \cdot & \cdot \\ a_{m1} & a_{m2} & a_{m3} & \cdots & a_{mn} \end{bmatrix} \begin{bmatrix} x_1 \\ x_2 \\ x_3 \\ \cdot \\ x_n \end{bmatrix} = \begin{bmatrix} b_1 \\ b_2 \\ b_3 \\ \cdot \\ b_m \end{bmatrix}$$

```
Editor - E:\Google Drive\lectures_TUD\matlab_script_ade_fem\ade_solver.m
File Edit Text Go Cell Tools Debug Desktop Window Help
- 1.0 + ÷ 1.1 x %>% %>% %>%
85 - LHS = sparse(nn,nn);
86 - RHS = sparse(nn,1);
87 - str = ['Time step ', num2str(ti), ' at time ', num2str(time_steps(t
88 - disp(str);
89 - dt = time_steps(ti+1) - time_steps(ti);
90 - % loop over all the elements,
91 - for ie = 1 : ne
92 -     % get the coordinates of connecting nodes
93 -     sctr = elements(ie,:);
94 -     coord = nodes(sctr,:) ;
95 -     % local mass matrix
96 -     M = shapeshape_tri( coord ); % no coeff
97 -     % local advection matrix
98 -     Adv = shapeshape_tri( coord, [vel;0.0]);%
99 -     % local dispersion/diffusion matrix
100 -     Disp = dshapeshape_tri(coord, [Dt, 0.0; 0.0, 0.01*Dt]);
101 -     % add advection and dispersion matrix t
102 -     S = Adv + Disp;
103 -     % assemble to the LHS
104 -     l_lhs= ((1.0/dt)*M + theta * S);
105 -     LHS(sctr,sctr) = LHS(sctr,sctr) + l_lhs;
106 -     % assemble to the RHS
107 -     l_rhs= ((1.0/dt)*M - (1-theta)* S) * u_pre(sctr);
108 -     RHS(sctr) = RHS(sctr) + l_rhs;
109 - end
110
script Ln 109 Col 8
```

Linear equation assembly

$$\begin{aligned} & \left(\frac{1}{\Delta t} M + \theta K \right) C^{n+1} \\ = & \underbrace{\left(\frac{1}{\Delta t} M + (1 - \theta) K \right)}_{A} \cdot C^n + Q = b \end{aligned}$$

$$Ax = b$$

$$\begin{bmatrix} a_{11} & a_{12} & a_{13} & \dots & a_{1n} \\ a_{21} & a_{22} & a_{23} & \dots & a_{2n} \\ a_{31} & a_{32} & a_{33} & \dots & \cdot \\ \cdot & \cdot & \cdot & \dots & \cdot \\ a_{m1} & a_{m2} & a_{m3} & \dots & a_{mn} \end{bmatrix} \begin{bmatrix} x_1 \\ x_2 \\ x_3 \\ \cdot \\ x_n \end{bmatrix} = \begin{bmatrix} b_1 \\ b_2 \\ b_3 \\ \cdot \\ b_m \end{bmatrix}$$

```
Editor - E:\Google Drive\lectures_TUD\matlab_script_ade_fem\ade_solver.m
File Edit Text Go Cell Tools Debug Desktop Window Help
- 1.0 + ÷ 1.1 x % % !
85 - LHS = sparse(nn,nn);
86 - RHS = sparse(nn,1);
87 - str = ['Time step ', num2str(ti), ' at time ', num2str(time_steps(t
88 - disp(str);
89 - dt = time_steps(ti+1) - time_steps(ti);
90 - % loop over all the elements,
91 - for ie = 1 : ne
92 - % get the coordinates of connecting nodes
93 - sctr = elements(ie,:);
94 - coord = nodes(sctr,:) ;
95 - % local mass matrix
96 - M = shapshape_tri( coord ); % no coeff
97 - % local advection matrix
98 - Adv = shapedshape_tri( coord, [vel;0.0]);%
99 - % local dispersion/diffusion matrix
100 - Disp = dshapedshape_tri(coord, [Dt, 0.0; 0.0, 0.01*Dt]);
101 - % add advection and dispersion matrix t
102 - S = Adv + Disp;
103 - % assemble to the LHS
104 - l_lhs= ((1.0/dt)*M + theta * S);
105 - LHS(sctr,sctr) = LHS(sctr,sctr) + l_lhs;
106 - % assemble to the RHS
107 - l_rhs= ((1.0/dt)*M - (1-theta)* S) * u_pre(sctr);
108 - RHS(sctr) = RHS(sctr) + l_rhs;
109 - end
```

Impose Boundary Condition

Assuming we know the boundary value on one of the node, how can we solve the linear equation in a way that we get the desired value on this node?

$$Ax = b$$

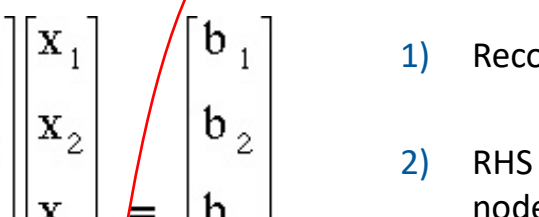
$$\begin{bmatrix} a_{11} & a_{12} & a_{13} & \dots & a_{1n} \\ a_{21} & a_{22} & a_{23} & \dots & a_{2n} \\ a_{31} & a_{32} & a_{33} & \dots & \cdot \\ \cdot & \cdot & \cdot & \cdot & \cdot \\ a_{m1} & a_{m2} & a_{m3} & \dots & a_{mn} \end{bmatrix} \begin{bmatrix} x_1 \\ x_2 \\ x_3 \\ \cdot \\ x_n \end{bmatrix} = \begin{bmatrix} b_1 \\ b_2 \\ b_3 \\ \cdot \\ b_m \end{bmatrix}$$

The procedure is as follows:

- 1) Record the index of boundary node, say "i".
- 2) RHS vector minus the multiplication of fixed boundary node value with the i-th column of LHS matrix.
- 3) Record the i-th row and column entry value in LHS as TMP.
- 4) Make i-th row of LHS all zeros.
- 5) Make i-th column of LHS all zeros.
- 6) Overwrite i-th value in RHS vector as TMP times fixed boundary value
- 7) Overwrite i-th row and column entry value in LHS matrix as xii.

Impose Boundary Condition

Taking the following linear equation as an example (represent a 1D Groundwater flow):

$$\begin{pmatrix} 1/2 & -1/2 & 0 & 0 & 0 \\ -1/2 & 3/2 & -1 & 0 & 0 \\ 0 & -1 & 4/3 & -1/3 & 0 \\ 0 & 0 & -1/3 & 2/3 & -1/3 \\ 0 & 0 & 0 & -1/3 & 1/3 \end{pmatrix} \begin{Bmatrix} h_1 \\ h_2 \\ h_3 \\ h_4 \\ h_5 \end{Bmatrix} = \begin{Bmatrix} 0 \\ 0 \\ 0 \\ 0 \\ 0 \end{Bmatrix}$$

After imposing boundary nodes?

$$\begin{pmatrix} _ & _ & _ & _ & _ \\ _ & _ & _ & _ & _ \\ _ & _ & _ & _ & _ \\ _ & _ & _ & _ & _ \\ _ & _ & _ & _ & _ \end{pmatrix} \begin{Bmatrix} h_1 \\ h_2 \\ h_3 \\ h_4 \\ h_5 \end{Bmatrix} = \begin{Bmatrix} _ \\ _ \\ _ \\ _ \\ _ \end{Bmatrix}$$

What result do you get by solving this linear equation system?

Peclet Number

Peclet number is defined as the ratio of the rate of advection to the rate of dispersion/diffusion.

$$Pe = \frac{vL}{D}$$

- Peclet number is dimensionless.
- Peclet number reflects the ratio of advection versus diffusion. If less than one, then diffusion dominated. If more than one, then advection dominated.
- Typically, the characteristic length L refers to the length of an element.
- For the accurate solution of finite element method, the Pe number has to be kept to be less than 2.

Courant Number

AKA Courant–Friedrichs–Lewy condition

$$1D \quad Cr = \frac{v_x \Delta t}{\Delta x} \leq Cr_{max}$$

$$2D \quad Cr = \frac{v_x \Delta t}{\Delta x} + \frac{v_y \Delta t}{\Delta y} \leq Cr_{max}$$

- Courant number is also dimensionless
- Cr_max is typically constrained to be 2, i.e. in a given time step, one particle should not travel beyond the neighbouring element.
- Necessary condition when using explicit time integration scheme with the finite difference method.